

ASW201

AES 2x1 Clean Audio Switch

INSERTERS

SWITCHES

CONVERSION

KEYERS

MIXERS

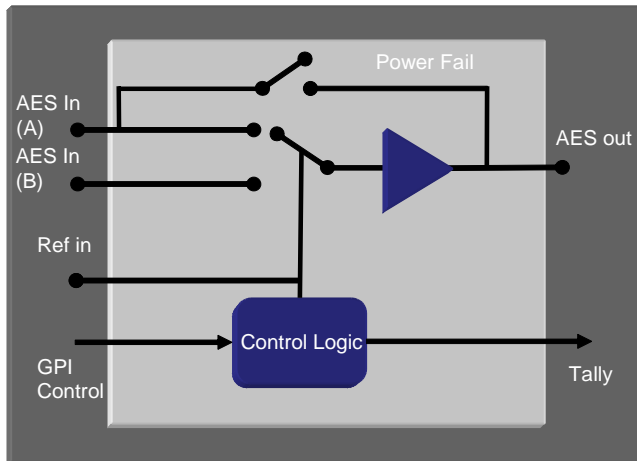

Seamless LIVE emergency switching

Automatic switching on signal loss

GPI switch control

Video or AES reference

Power fail relay bypass

The ASW201 allows switching between two AES digital audio signals. The AES signals are decoded and aligned to a reference signal, ensuring a clean switch is achieved. This ensures that audio equipment further down stream is not disrupted and that there is no audible disturbance.



The card can be configured to manually or automatically switch. In auto-switch mode, the card will switch back to the primary input once a valid signal has been established for a reasonable period of time. In manual mode an external GPI can drive the change between sources.

Up to 6 cards can be fitted in a 1U frame, 12 can be fitted in a 3U. It can be used with Microvideo's ESW201 digital video switching modules, allowing a single box solution for audio and video switching.

Its compact size allows multiple channels to be put into a single frame. It can be used with Microvideo's ESW201 digital video switching modules, allowing a single box solution for audio - video switching.

MicroVideo

Copley Hill Farm
Babraham
Cambridge
England, CB23 3GN
t: +44 (0) 1223 834119
f: +44 (0) 1223 834471
w: www.microvideo.co.uk

ASW201

Technical Information

INSERTERS

SWITCHES

CONVERSION

KEYERS

MIXERS

- Inputs:** 2 x AES on 15 way 'D' connector socket.
To SMPTE 259M (EBU Tech 3267-E). 24 or 20 bit AES/EBU as described in EBU Tech 3250-E (or AES-3-1992), with 48Khz sample rate. Referred to as input A (main) and B (secondary).
- 1 x Analogue video (PAL/NTSC), 1V into 75R (optional internal termination)
Note : The card can be set to use the main AES input as reference, however using the video 'Ref' input ensures that the output timing always remains fixed, regardless of variation on the inputs.
- Outputs:** 1 x AES on 15 way 'D' connector socket.
To SMPTE 259M (EBU Tech 3267-E). 24 or 20 bit AES/EBU as described in EBU Tech 3250-E (or AES-3-1992), with 48Khz sample rate.
- Control:** DIP switches on the card edge can set the following parameters:
- | | |
|--------------------------------|-------------------------------|
| Reference input selection | Manual/auto switching |
| Video standard (625/525 lines) | Test tone output off/on |
| Remote control enable | Relay bypass select (passive) |
| Switch between inputs | 20/24bit output selection |
- In "MANUAL" switch mode a closing contact to ground on the GPI input causes a switch to input B.
In "AUTO" switch mode the card will switch to input B when the audio on input A becomes invalid. In Auto mode switching can still be activated by the external GPI input. A tally output is provided which indicates switch status.
- Physical:** Eurocard size module for mounting in our 1U or 3U frames.
- Frames:** Up to 6 modules will fit in a Microvideo 1U frame and 14 in a 3U frame. They may be mixed with other Microvideo Series 200 boards in the same frame.
- Ordering:**
- | | |
|---------|--|
| ASW201 | 2x1 Clean Audio Switching Module for AES audio |
| -UB | Optional unbalanced audio connections (BNC, in lieu of D type) |
| FR1U-10 | 1U rack mounting frame for series 200 cards (single PSU) |
| FR1U-20 | 1U rack mounting frame for series 200 cards (dual PSU) |
| FR3U-10 | 3U rack mounting frame for series 200 cards (single PSU) |
| FR3U-20 | 3U rack mounting frame for series 200 cards (dual PSU) |
| -CB | Control Bus wiring for 3U frame (required for GPI connections) |
- Related products:** ESW201, ESW201-B, ESW201-S, HDS201, HDS201-S, RSW204, VSW201.

MicroVideo

Copley Hill Farm
Babraham
Cambridge
England, CB22 3GN
t: +44 (0) 1223 834119
f: +44 (0) 1223 834471
w: www.microvideo.co.uk